

SINTEF Building and Infrastructure confirms that

Fibo Bathroom Wall Panel

has been found to be fit for use in Norway and to meet the provisions regarding product documentation given in the regulation relating to the marketing of products for construction works (DOK) and regulations on technical requirements for building works (TEK), with the properties, fields of application and conditions for use as stated in this document

1. Holder of the approval

Fibo AS
 Industrivien 2
 4580 Lyngdal
 Tlf.: 38 13 71 00
www.fibo.no

2. Product description

Fibo bathroom wall panel, see fig. 1, is a watertight lining system based on plywood panels coated with high-pressure laminate on the front side and a transverse laminate on the rear side. The panels are made from plywood and consist of 7 sheets of wood according to NS-EN 13986, glued with waterproof adhesive. The front of the panels is covered with 0,85 mm high-pressure laminate, and the backside is covered with a 0,73 mm thick balancing layer. Extruded aluminium or PVC assembly profiles are included in the panel system.

Standard dimensions are 2400 mm length and 600 mm width. Panel thickness is 10,2 mm. The density is 790 kg/m³. Tolerances are shown in table 1.

Table 1

Tolerances for production of Fibo bathroom wall panel

Property	Requirement	Test Method
Length	± 1,0 mm	NS-EN 324-1
Width	± 0,5 mm	
Thickness	± 0,4 mm	
Squareness	≤ 1,0 mm	Diagonal deviation
Edge straightness	Max 0,8 mm	NS-EN 324-2
Lipping tongue/groove	≤ 0,15 mm	-

The long sides of the panels are profiled as shown in fig. 2, with an integrated locking profile "Aqualock". The short ends have inclined edges.

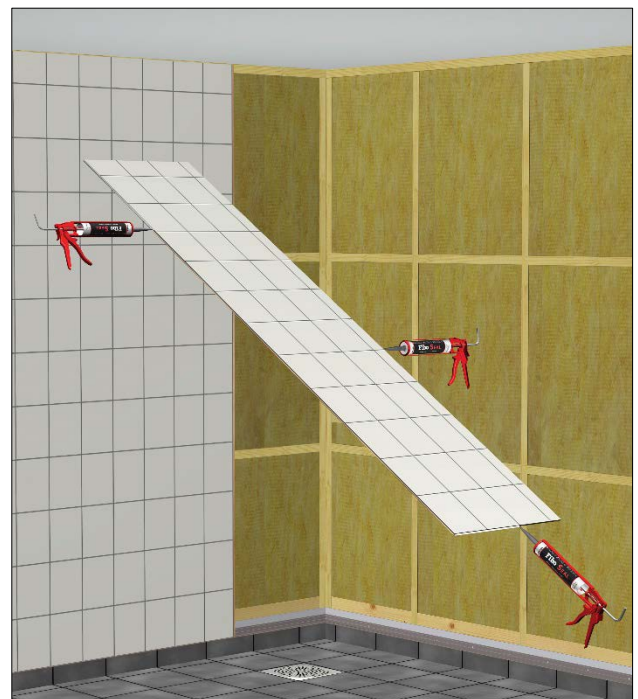

Fig. 1. Fibo bathroom wall panel system

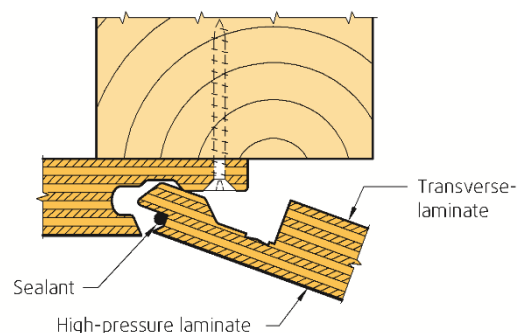

Fig. 2
 Fibo bathroom wall panel is designed with Aqualock system

3. Fields of application

Fibo bathroom wall panel can be used on walls in sanitary rooms as a waterproof lining. The panels can also be used in cloakrooms, washrooms, laundries, cleaning plants, laboratories, kitchens etc. The panels can be fixed directly to the wall frames or battens, included walls below ground level.

Tabell 2

Product characteristics for Fibo bathroom wall panel verified by testing

Property	Result	Test method
Water vapour transmission, front side S_d – value ¹⁾	14 m	NS-EN 12572
Water tightness at 1,5 bar water pressure for 7 days	Passed	NS-EN 14891, Annex A.7
Water tightness at penetrations in wall ²⁾	Passed	ETAG 022 Annex E
Bridge building capacity: - tensile strength - shear strength	2 mm – passed 2 mm – passed	ETAG 022, annex B
Dimensional changes in panel plane associated with changes in relative humidity: - Width, 30 – 90 % RF - Length, 30 – 90 % RF - Width, 90 – 30 % RF - Length, 90 – 30 % RF	1,9 mm/m 1,9 mm/m -1,6 mm/m -1,7 mm/m	NS-EN 318
Swelling of thickness after 24 hours immersion in water	2,8 %	NS-EN 317
Tensile strength perpendicular to the plane of the board	2,3 N/mm ²	NS-EN 319
Resistance to axial withdrawal of screws	1740 N	NS-EN 320
Bending strength: - longitudinal direction - cross direction	1200 Nmm/mm 1400 Nmm/mm	NS-EN 310
Bending strength, EI: - longitudinal direction - cross direction	690 kNmm ² /mm 720 kNmm ² /mm	NS-EN 12089
Resistance to scratches	Passed	ETAG 022, Annex C
Cleaning ability	Passed	SS 92 36 14
Formaldehyde release	Class E1	NS-EN 13986

¹⁾ Test conditions: 93 % RH / 50 % RF vat 23 °C

²⁾ Penetrations: copper pipes Ø 15 mm, PP pipe Ø 110 mm and wall boxes Ø 46 mm

4. Properties

Material properties

Fibo bathroom wall panels are tested according to ETAG 022, "Guideline for European Technical Approval of watertight covering kits for wet room floors and or walls", Part 3: Inherently watertight board. Table 2 shows results from testing.

Fire properties

Fibo bathroom wall panel including sealant Fibo Seal has fire class D-s1,d0, according to EN 13501-1, on a wooden underlay min. 12 mm and min. density 630 kg/m³, or other underlay with min. fire class A1 or A2-s1,d0.

5. Environmental aspects

Hazardous substances

The product contains no hazardous substances with priority in quantities that pose any increased risk for human health and environment. Chemicals with priority include CMR, PBT or vPvB substances.

Effect on indoor environment

The product is not regarded as emitting any particles, gases or radiation that have a perceptible impact on the indoor climate, or to have any significant impact on health.

Waste treatment/recycling

Fibo bathroom wall panel shall be sorted as residual waste on the building/demolition site. The product shall be delivered to an authorized waste treatment plant for energy recovery.

Environmental declaration

An environmental performance declaration (EPD) according to EN 15804 is issued to Fibo bathroom wall panel. For full environmental declaration see EPD nr. NEPD00281N, www.epd-norge.no

6. Special conditions for use and installation

Storage and conditioning

Fibo bathroom wall panels shall be stored under dry conditions on a levelled substrate, front side to front side for surface protection. The panels shall be stored with packaging at room temperature for 3 days prior to installation. Humidity content of the panel core shall be <15 % at installation.

Underlying base

The underlying base for installation of Fibo bathroom wall panels shall comply with the requirements for directional- and surface-tolerances given in NS 3420-1, tolerance class PB.

Installation on timber framework

The studs spacing shall be max. c/c 0,6 m, and horizontal battens shall have spacing max. c/c 0,8 m. Extra noggings shall be used if heavy objects, for instance washstand, shall be installed.

The panels shall be fixed to the studs/battens by zinc coated ring shanked special nails or by screws, spacing c/c 200 mm, as shown in fig. 1, nails or screws no closer than 35 mm from the top or bottom of the panel.

Power tools must be used with caution not to damage the panels.

Installation on concrete or brick walls

When installed on concrete or brick walls the panels shall be fixed to vertical and horizontal battens with dimensions min. 23 mm x 48 mm. The battens shall be installed c/c 0,8 m with the wide side flat. Distance between battens shall be 0,8 m, as described above for frame work walls. A capillary

obstructing layer, for instance strips of tar paper, shall be installed between concrete/brick wall and the battens.

Wet areas

For wet areas all vertical joints and profiles shall be sealed using a wet area sealant as illustrated in fig. 1 - 4. To ensure proper water tightness excess sealant shall be visible along the profile. Excess sealant must be wiped away.

All panel ends are to be sealed with one of the sealants listed in Table 3 prior to assembly.

Sealing of all joints shall be performed according to manufacturer's instructions.

Sealants approved for use are listed in Table 3. These sealants has been tested with Fibo bathroom wall panels according to ETAG 022, "Guideline for European Technical Approval of watertight covering kits for wet room floors and or walls", Part 3: Inherently watertight board. The listed sealants comply with present environmental requirements.

Table 3
Sealants approved for use with Fibo bathroom wall panels

Wet area sealant	Aluminium profiles	PVC-profiles
Fibo Seal	x	x
Soudaseal 215 LM	x	x
Optiform Baderomsplate Montasje	x	x
Casco AquaSeal	x	
CT1	x	x

Penetrations in wet areas

Water tightness around wall boxes are ensured by using one of following methods:

- Sleeve delivered with the wall box is to be attached to the bathroom panel using one of the sealants listed in table 3. See Fig 3.
- Tightening ring and gasket delivered with wall box is installed as illustrated in Fig. 4.

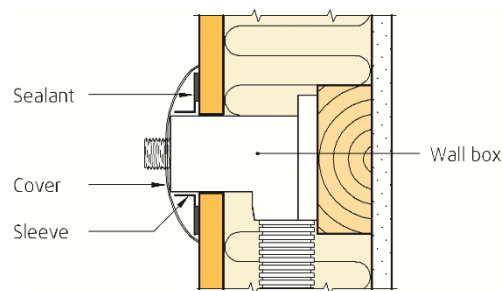

Fig. 3
Installation of wall box with sleeve

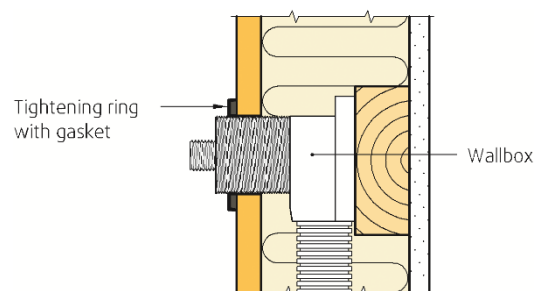

Fig. 4
Installation of wall box with tightening ring and gasket

Vapour barrier in exterior walls

Fibo bathroom wall panels meet the requirements to water vapor transmission for walls facing outdoor environment or unheated rooms. Walls shall not have any vapor barrier in addition to Fibo bathroom wall panel.

Maintenance/cleaning

Fibo bathroom wall panels are to be cleaned using a wet cloth or using a mild cleaner without rubbing components.

7. Factory production control

The product is produced by Fibo AS, Industrivien 2, 4580 Lyngdal, Norway.

The holder of the approval is responsible for the factory production control in order to ensure that the product is produced in accordance with the preconditions applying to this approval.

The manufacturing of the product is subject to continuous surveillance of the factory production control in accordance with the contract regarding SINTEF Technical Approval.

The manufacturer holds a quality system certified by Det Norske Veritas in accordance to ISO 9001:2008, certificate no. 2002-OSL-AQ-7219.

8. Basis for the approval

The approval is based on the properties documented in these reports:

- SINTEF Building and Infrastructure. Report SBF2016F0539 dated 10.11.2016
- SINTEF NBL as, Report 102010.02/12.04, dated 04.07.2012.
- SINTEF Building and Infrastructure. Report 3B052216 dated 09.01.2012.
- SINTEF Building and Infrastructure. Report 3B0460 dated 28.02.2011
- SINTEF Building and Infrastructure. Report 3B0567 dated 20.09.2011.
- SINTEF Building and Infrastructure. Report 3B053901 dated 23.06.2011.
- SINTEF Building and Infrastructure. Report 3B0461 dated 23.03.2011.
- SINTEF Building and Infrastructure. Report 3B056701 dated 20.09.2011.
- SINTEF Building and Infrastructure. Report 3D0256.01 dated 01.09.2008.
- Norwegian Building Research Institute. Report O-9580 dated 25.11.99.
- Norwegian Building Research Institute. Report KO 40340 dated 10.02.00 and KO 40341 dated 10.02.00.

9. Marking

The product shall be marked with the manufacturers name, product name and date of production. The marking may be fixed directly on the panels or on the packaging. The approval mark for Technical Approval No. 2289 may also be used.



Approval mark

10. Liability

The holder/manufacturer has sole product responsibility according to existing law. Claims resulting from the use of the product cannot be brought against SINTEF beyond the provisions of Norwegian Standard NS 8402

for SINTEF Building and Infrastructure

Marius Kvalvik
Godkjenningsleder